

GENERAL PURPOSE ENGINES

GP160H / GP200H

HONDA

The Power of Dreams

New

Affordable and Reliable Power

***GP* 160**

***GP* 200**



Horizontal shaft gasoline (petrol) engine

PTO SHAFT DIMENSIONS

Q-type

STANDARD TYPE

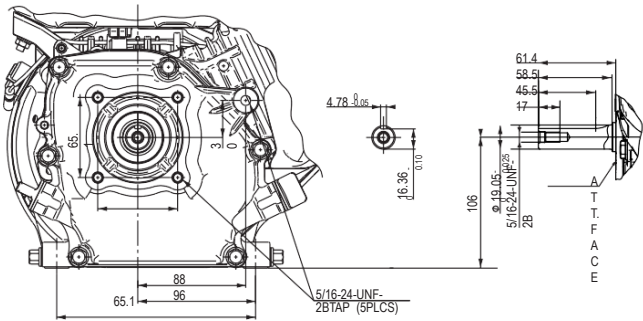

V-type

STANDARD TYPE

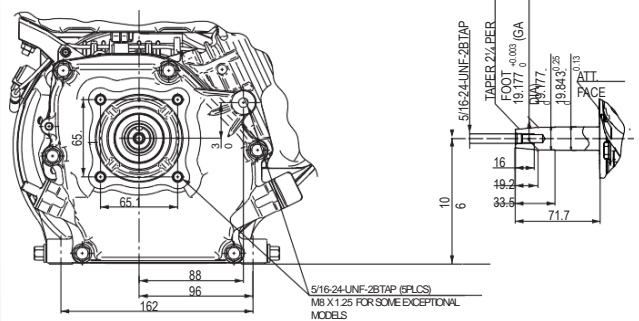

PERFORMANCE CURVES

GP 160

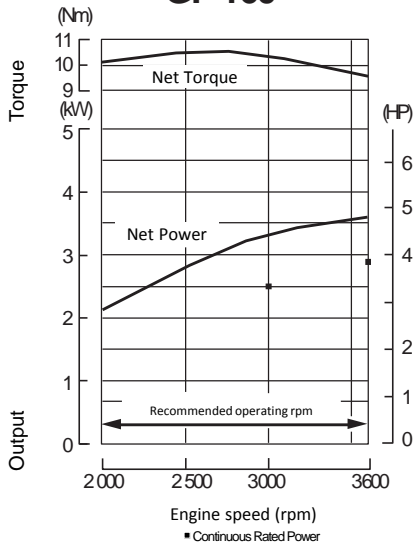

GP 200

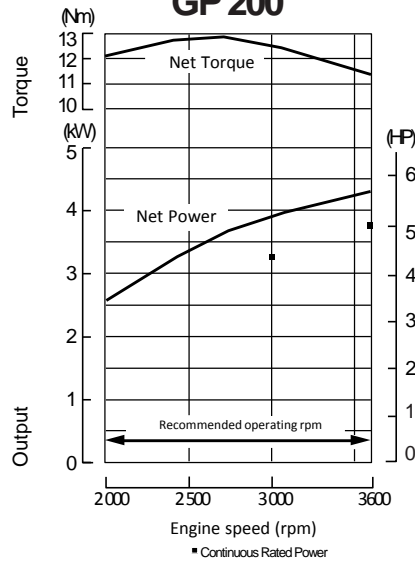

SPECIFICATIONS

Model	GP160	GP200
Engine type	Air cooled 4-stroke OHV petrol engine, 25° inclined cylinder, horizontal shaft, cast iron sleeve	Air cooled 4-stroke OHV petrol engine, 25° inclined cylinder, horizontal shaft, cast iron sleeve
Bore x stroke	68 x 45 mm	68 x 54 mm
Displacement	163 cm ³	196 cm ³
Compression ratio	8.5 : 1	8.5 : 1
Net power	3.6 kW (4.8 HP) / 3 600 rpm	4.3 kW (5.8 HP) / 3 600 rpm
Cont. rated power	2.5 kW (3.4 HP) / 3 000 rpm 2.9 kW (3.9 HP) / 3 600 rpm	3.3 kW (4.4 HP) / 3 000 rpm 3.7 kW (5.0 HP) / 3 600 rpm
Max. net torque	10.3 Nm / 1.05 kgfm / 2 500 rpm	12.4 Nm / 1.26 kgfm / 2 500 rpm
Ignition system	Transistorised	Transistorised
Starting system	Recoil Starter	Recoil Starter
Fuel tank capacity	3.1 l	3.1 l
Fuel consumption at rated power	1.4 L/hr - 3 600 rpm	1.7 L/hr - 3 600 rpm
Engine oil capacity	0.6 l	0.6 l
Dimensions (L x W x H)	314 x 363 x 335 mm	323 x 378 x 335 mm
Dry weight	15.1 kg	16.1 kg

The power rating of the engine indicated in this document is the net power tested on a production engine for the engine model and measured in accordance with SAE J1349 at a specified rpm. Mass production engines may vary from this value. Actual power output for the engine installed in the final machine will vary depending on numerous factors, including the operating speed of the engine in application, environmental conditions, maintenance, and other variables.